

MM-64 Triple Option Picker

This new picker that has all three drive options, including the Memco® Triple Option Picker Hub with the patented bearing isolator technology for extended life and maintenance free! The Model MM-64 has a full 360° rotation cabinet to maximize ease of maintenance, sanitation and finger installation. The bevel gear adjustments offer precise picker "Pocket" control to allow a precise adjustment to bird size and conditions. Motor Position adjustment is made easy by using a horizontal sliding motor-mounting base for quicker setup and adjustment.

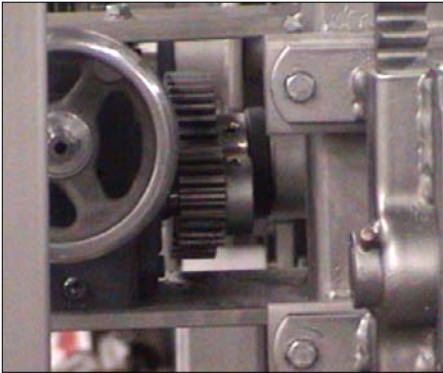
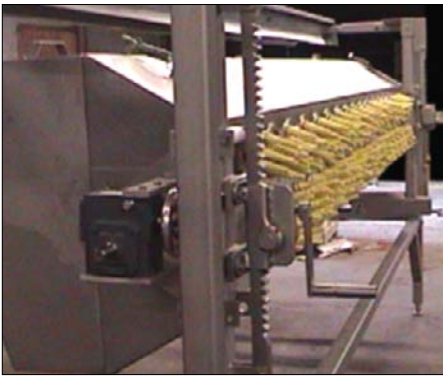

TRIPLE OPTION PICKER

- Totally maintenance free bearing housings.
- Cooler running hubs.
- Much longer lasting drive-train than existing pickers.
- Incorporates the design technology of the triple option picker hub into a complete picker package.
- Includes the advantage of receiving the proven dependability of the triple option hub.
- Patented bearing isolator design totally isolates the internal components of the hub from all contaminants using either the flat belt, "v" belt or the patented cog belt drive system.
- Extends belt life as well as motor life using the patented cog belt design.
- Now offering the proven outstanding performance of the franklin hydro-duty motor for the poultry industry with one-year warranty.
- Superior savings with efficiency and increased production.

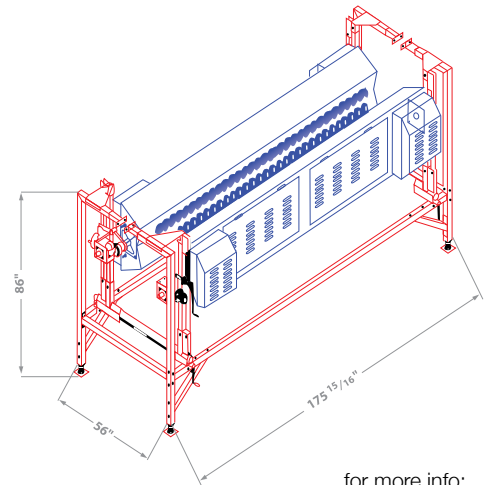

for more info:

CALL
800.873.9687

VISIT
mandmpoultry.com

Hollister, MO
Gadsden, AL
Ft. Smith, AR
Springdale, AR



■ 800.873.9687
■ mandmpoultry.com